



Star Pop! Mystery Quilt

by Kimberly Einmo

Quilt size: 54" x 54"

Skill level: Intermediate

You've make some fun fabric choices with this new, original mystery quilt. Whether you've made a mystery quilt in the past or if this is your very first one, you'll love this new design, which is a combination of three traditional-style pieced blocks with a surprising, creative twist! While the blocks themselves are not difficult to piece, you'll be amazed at the dynamic secondary pattern when the blocks are sewn together! Choose your own fabrics by carefully selecting the color values listed on the supply list. This design has a special option. You can choose two different background fabrics (fabrics #2 and #3) or just one background fabric. Still not sure? Take a photo of your fabrics and email it to Kimberly at Kimberly@kimberlyeinmo.com for her expert advice! Kimberly has designed the entire process to be stress-free. The rule of thumb is this: if your fabrics have good contrast, look great when laid out together, and match the values provided on the supply list, they'll look beautiful when sewn together. Come enjoy a fantastic day of stitching and create a one-of-a-kind, beautiful quilt you'll cherish!

Supply List

NOTE: Kimberly will have a few of her specialty rulers to lend in class and new rulers for sale at a discount.

- **EZ Flying Geese Ruler** by Kimberly Einmo
- **EZ Precision Precuts Ruler OR EZ Jelly Roll Ruler** by Kimberly Einmo
- 45 or 60 mm rotary cutter with a new, sharp blade
- Cutting mat (larger than 12" is best)
- Rotary cutting ruler (your favorite size ruler for cutting yardage and strips)
- Square ruler, 10½" or larger with a 45-degree line. Optional for class, but necessary for squaring-up blocks after all the blocks are completed outside of class.
- 50-wt. cotton sewing thread to match your background fabric (*Kimberly loves Aurifill!*)
- Basic sewing supplies including anything that will make your classroom sewing experience more enjoyable!
- A Post-it® Notes pad (*especially helpful*).
- Ziploc® baggies to store your cut pieces.

Fabric Requirements and Instructions

- Create a legend of your fabrics on the fabric cutting chart. Attach a small piece of each fabric in the square next to the corresponding fabric number. You'll be very glad you took the time to do this!
- Cut your fabrics as directed below prior to class. (*Cut all strips across the WOF, selvage to selvage.*) Label pieces with the size and Clue #. To keep all your cut strips and fabric pieces organized; put them in Ziploc baggies and label them with the clue number.
- Bring all fabrics and leftover pieces to class! (You do not need to bring your batting, backing, or binding to class.)

Cutting and Preparation Prior to Class

- If you will do a bit of pre-sewing prior to coming to class, you'll be well on your way to completing the quilt top! However, if you cannot sew your pieces before class day, there's a lot to learn and you'll still complete a great deal of the quilt top construction.
- For Clue #1, which is meant to be completed at home, you must choose the specialty ruler (**EZ Flying Geese Ruler** by Kimberly Einmo) OR the traditional method to cut some of your pieces. You may order the ruler at www.kimberlyeinmo.com and instructions are provided so you'll know how to use it. If you would like to see a video demonstrating this technique, please sign up for Kimberly's FREE CRAFTSY class, the 2015 SUMMER Block of the Month at www.craftsy.com. Of course, you don't have to make the quilt and it costs nothing to sign up. Kimberly demonstrates how to use the ruler in to make half-square triangles the first month (July).

Cutting Chart *Colors listed below in italics are the colors I used for my quilt. Choose **your** favorite fabrics and colors. As long as you closely follow the VALUES as listed, your quilt will be beautiful!*

Abbreviations used:

EZFG = **EZ Flying Geese Ruler**

EZJR = **EZ Jelly Roll Ruler**

RST = right-sides together

WOF = width of fabric

HST = half-square triangle

One of the things that makes this quilt extra special is the use of two different background fabrics (fabrics #2 and #3). It is important that they are close in value (but they can be different colors) and are solids, batiks, or tone-on-tones prints. However, if you choose to use only one background fabric; simply combine the cutting instructions for fabrics #2 and #3 using the same fabric.

LEGEND	FABRIC #	COLOR/ VALUE	YARDAGE	CUTTING INSTRUCTIONS
	1	Multi-color, main print	1/3 yard	<ul style="list-style-type: none"> • Cut 1 – 3½" strip. [Clue 5] • Cut 1 – 4½" strip; subcut 8 – 4½" x 4½" squares. [Use 4 squares for Clue 2 and 4 squares for Clue 4]
	2	LIGHT (Background) <i>Light yellow</i>	7/8 yard	<ul style="list-style-type: none"> • Cut 1 – 4½" strips (if using the EZFG method for HSTs) OR cut 1 – 4-7/8" strip [Clue 1] • Cut 2 – 4½" strips; subcut 16 – 4½" squares. [Clue 2] • Cut 2 – 2" strips. [Clue 5] • Cut 3 – 3½" strips; subcut 16 – 3½" x 6½" rectangles. [Clue 6]
	3	LIGHT (Background) <i>Aqua</i>	1¾ yards	<ul style="list-style-type: none"> • Cut 2 – 2½" strips; use Side A to cut 16 triangles (if using the EZFG method for the Flying Geese units) OR cut 1 – 4½" strip; subcut 12 – 2½" x 4½" rectangles (if using the traditional method). [Clue 3] NOTE: See Clue 3 for how to use the EZFG ruler. • Cut 1 – 4½" strip; subcut 4 – 4½" x 4½" squares. Cut squares 1x diagonally to yield 8 triangles. [Clue 4] • Cut 4 – 2½" strips; subcut 16 – 2½" x 4½" rectangles AND 16 – 2½" x 2½" squares. [Clue 4] • Cut 2 – 2" strips. [Clue 5] • Cut 3 – 3½" strips; subcut 16 – 3½" x 6½" rectangles. [Clue 6] • Cut 6 – 3½" strips for outer border (these will be pieced together later.) [Clue 6]
	4	MEDIUM LIGHT <i>Gold</i>	½ yard	<ul style="list-style-type: none"> • Cut 2 – 4½" strips; subcut 16 – 2½" x 4½" rectangles. [Clue 4] • Cut 2 – 2" strips. [Clue 5] • Cut 1 – 3½" strip. [Clue 5]
	5	MEDIUM <i>Green</i>	1/3 yard	<ul style="list-style-type: none"> • Cut 1 – 1¾" strip; subcut 4 – 1¾" x 7" rectangles. [Clue 4] • Cut 3 – 2" strips. [Clue 5]
	6	MEDIUM DARK <i>Red</i>	½ yard	<ul style="list-style-type: none"> • Cut 2 – 3¾" strips; subcut 16 – 3¾" squares. [Clue 2] • Cut 3 – 2" strips. [Clue 5]
	7	DARK <i>Blue</i>	½ yard	<ul style="list-style-type: none"> • Cut 1 – 4½" strip (if using the EZFG method for HSTs) OR cut 1 – 4-7/8" strip (if using the traditional HST method). [Clue 1] • Cut 2 – 2½" strips; fold strips RST. Use Side B of the EZFG ruler to cut 16 PAIRS of triangles (if using the EZFG method for the Flying Geese units) OR cut 1 – 2½" strip; subcut 16 – 2½" x 2½" squares (if using the traditional method). [Clue 3]
<i>Not needed for class</i>	Backing		4 yards	<ul style="list-style-type: none"> • Cut 2 panels 32" x 64" and piece for the backing.
<i>Not needed for class</i>	Batting		---	64" x 64"
<i>Not needed for class</i>	Binding		½	<ul style="list-style-type: none"> • Cut 6 – 2¼" strips for binding.

CLUE 1

Choose Kimberly's **EZ Flying Geese Ruler** method or the traditional method and cut your strips as outlined in the Cutting Chart above.

Here's what you'll make:

- 16 – 4½" (unfinished) HSTs from fabrics #2 and #7.

EZ Flying Geese Ruler method:

- Place 1 – 4½" strip each of fabrics #2 and #7 RST.
- Use Side B of the **EZ Flying Geese Ruler** to cut 8 – 4½" triangle pairs (16 triangles total) for HSTs.
- Chain stitch the units together on the long edge of the triangles.
- Press the triangle units closed to set the seams; then press seams toward fabric #7.
- Units should measure 4½" x 4½" (unfinished). Trim all dog ears and square-up if necessary.
- Make 16.

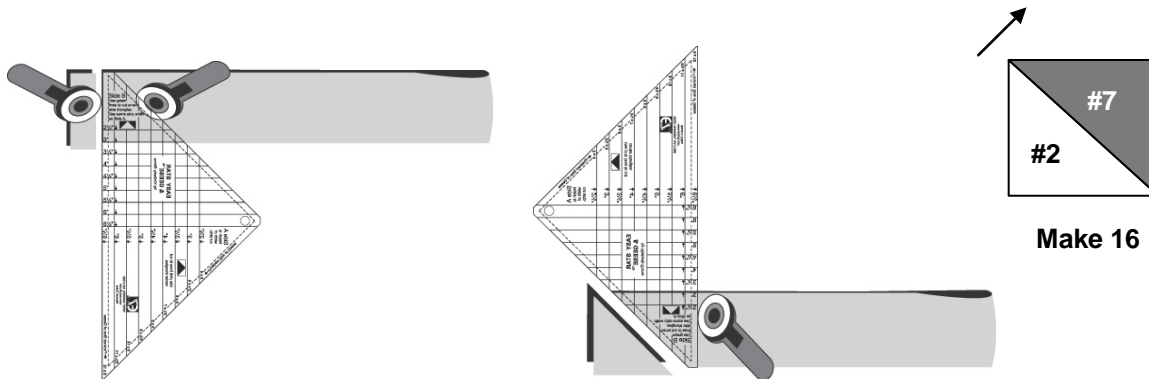

Traditional method:

- Place 8 – 4 7/8" squares each of fabrics #2 and #7 RST.
- Draw a diagonal line on the back of the fabric #2 square and stitch ¼" on both sides of the diagonal line.
- Cut on the drawn line.
- Press the seams toward fabric #7.
- The HSTs should measure 4½" x 4½" (unfinished). Trim the dog ears and square-up if necessary.
- Make 16.

