



Riders to the Stars Mystery Quilt

by Kimberly Einmo

Quilt size: 55" x 55"

Skill level: Intermediate



Do you remember the Barry Manilow song, *Riders to the Stars*? It was the inspiration when I designed this stunning new mystery quilt! In class, I'll teach you to use the **Precision Flying Geese & HST Ruler** plus a new assembly technique. While the blocks and units are not difficult to piece, you'll be delighted by the secondary pattern that is revealed when the blocks are sewn together! Choose your own fabrics by following the color **values** listed on the supply list. If you would like guidance on your fabric choices, email a photo to me at Kimberly@Kimberlyeinmo.com. For my quilt I used a dark background fabric, but you may choose a light background and follow the values as listed on the supply list. The rule of thumb is this: if your fabrics have good contrast and look great together, they'll look beautiful when sewn together. It's going to be a fun-tastic day of sewing in class as we make our way to the stars!

Supply List

NOTE: I will have the newest versions of my rulers in class for sale at a discount. If you already have my EZ Flying Geese Ruler or the EZ Jelly Roll Ruler, these will work.

- **Precision Flying Geese & HST Ruler** by Kimberly Einmo
- 45mm or 60mm rotary cutter with a new, sharp blade
- Cutting mat (larger than 12" is best)
- Rotary cutting ruler (the **Precision Jelly Roll Ruler** or **Precision Precuts Ruler** by **Kimberly Einmo** or your favorite size ruler for cutting yardage and strips)
- 50-wt. cotton sewing thread to match your background fabric
- Basic sewing supplies including anything that will make your classroom sewing experience more enjoyable!
- Post-it® Notes are handy to have in class but optional
- Ziploc® baggies to store your cut pieces

Fabric Requirements and Instructions

- Create a legend of your fabrics on the fabric cutting chart on page 2. Attach a small piece of each fabric in the square next to the corresponding fabric number. You'll be very glad you took the time to do this!
- Cut your fabrics as directed below prior to class. (*Cut all strips across the WOF, selvage to selvage.*) To keep all your cut strips and fabric pieces organized, put them in Ziploc baggies and label them with the fabric and clue numbers.
- Bring fabrics #1 - #6 and all leftover pieces to class. You do **NOT** need to bring batting, backing, or binding to class.

Cutting and Preparation Prior to Class

- Cut ALL the fabric as outlined in the cutting chart prior to class and label everything.
- If you complete Clues #1 and #2 prior to class, you'll be well on your way to completing the quilt top! However, if you choose not to complete these optional, preliminary clues at home, you'll still accomplish a lot in class.
- For Clue #2, you must choose either the specialty ruler method (**Precision Flying Geese & HST Ruler** by Kimberly Einmo) OR the traditional method to cut some of your pieces. You may order the ruler at www.kimberlyeinmo.com and instructions are provided so you'll know how to use it.

Cutting Chart Colors listed below in italics are the colors I used for my quilt. Choose **your** favorite fabrics and colors. If you closely follow the **VALUES** as listed, your quilt will be beautiful!

Abbreviations used:

FGHR = Precision Flying Geese & HST Ruler

PPR = Precision Precuts Ruler

HST = half-square triangle

JRR = Precision Jelly Roll Ruler

RST = right-sides together

WOF = width of fabric

Yellow highlights indicate clues to be done prior to class. **Blue highlights** indicate clues to be done in class.

LEGEND	FABRIC #	COLOR/ VALUE	YARDAGE	CUTTING INSTRUCTIONS
	1	DARK (Background)	2 yards	<ul style="list-style-type: none"> • Cut 5 – 3" strips WOF for border. Clue 6 • Cut 2 – 3" strips for four-patch units. Clue 1A • Cut 1 – 2½" strip for two-patch units. Clue 1B • If using the FGHR method, cut 1 – 5½" strip. OR, if using the traditional method, cut 1 – 5⅞" strip. Clue 2 • Cut 1 – 5½" strip. Clue 3 • Cut 1 – 4½" strip. Clue 4 • Cut 2 – 2½" strips. Clue 4 • Cut 2 – 10½" strips; subcut 8 – 5½" x 10½" rectangles. Trim the remaining strip to 8½". Cut 4 – 4½" x 8½" rectangles. Clue 5 • Cut 1 – 2½" strip; subcut 4 – 2½" x 4½" rectangles. Clue 5
	2	Multi-color, main print (Blocks and binding)	1 yard	<ul style="list-style-type: none"> • Cut 1 – 8⅞" strip; subcut 2 – 8⅞" squares. Cut squares 1x diagonally to yield 4 triangles. Clue 4 • Cut 1 – 4½" strip. Clue 4 • Cut 2 – 3½" strips. Clue 4 • Cut 6 – 2¼" strips for binding. (<i>Not needed for class.</i>)
	3	MEDIUM LIGHT	¾ yard	<ul style="list-style-type: none"> • If using the FGHR method, cut 2 – 5½" strips. OR, if using the traditional method, cut 2 – 5⅞" strips. Clue 2 • Cut 2 – 5½" strips. Clue 3. Cut 1 – 4½" square from strip and set aside for Clue 5 • Cut 1 – 3" strip; subcut 4 – 3" squares and set aside for Clue 6. Trim remainder of strip to 2½" and cut 4 – 2½" squares. Clue 5
	4	MEDIUM	½ yard	<ul style="list-style-type: none"> • Cut 2 – 3" strips for four-patch units. Clue 1A • Cut 1 – 2½" strip for two-patch units. Clue 1B • Cut 1 – 5½" strip. Clue 3
	5	MEDIUM	½ yard	<ul style="list-style-type: none"> • Cut 1 – 3½" strip. Clue 4 • Cut 2 – 2½" strips. Clue 4
	6	DARK	½ yard	<ul style="list-style-type: none"> • If using the FGHR method, cut 1 – 5½" strip. OR, if using the traditional method, cut 1 – 5⅞" strip. Clue 2 • Cut 2 – 5½" strips. Clue 3
<i>Not needed for class</i>	Backing		4 yards	<ul style="list-style-type: none"> • Cut 2 panels 32" x 64" and piece for the backing.
<i>Not needed for class</i>	Batting		---	64" x 64"

CLUE 1

Clue 1A

- Place 3" strips of fabrics #1 / #4 RST and sew on the long side to create a strip-set.
- Repeat to make a total of 2 fabric #1 / #4 strip-sets measuring 5½" in width after being sewn.
- Press the seams toward fabric #1.
- Rotate one strip-set and place RST on top of another strip-set, butting the seams together and matching opposite fabrics.
- Cut into 12 – 3" segment pairs (24 segments total); keep the pairs together.
- Sew the 3" segment pairs into four-patch units and press the seams to one side.
- Four-patch units should measure 5½" square unfinished. Square-up the units if necessary.
- **Make a total of 12 four-patch units.** Set aside for [Clue 6](#).

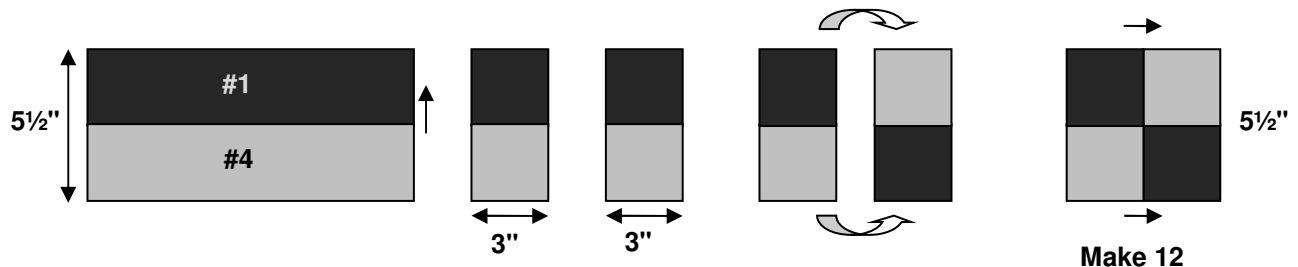

Clue 1B

- Place 2½" strips of fabrics #1 / #4 RST and sew on the long side to create 1 strip-set 4½" wide.
- Press the seams toward fabric #1.
- **Cut into 12 – 2½" segments.** Set aside for [Clue 5](#).

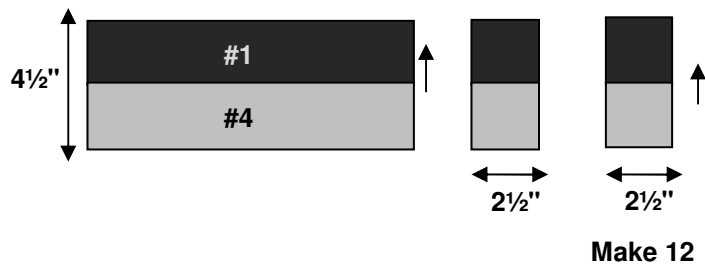

Try this...

When feeding your four-patch units underneath your presser foot, make sure the seam allowance on top is facing AWAY from you. Your presser foot and feed dogs will push them and "snuggle" your seams together to ensure perfect points in the center!

CLUE 2

Choose either the **Precision Flying Geese & HST Ruler** (aka **EZ Flying Geese Ruler**) or the **traditional method** to make HSTs as outlined in the cutting chart:

Here's what you'll make:

- 8 – 5½" (unfinished) HSTs from fabrics #1 and #3.
- 8 – 5½" (unfinished) HSTs from fabrics #3 and #6.

Precision Flying Geese & HST Ruler Method

- Place 1 – 5½" fabric #1 strip RST with 5½" fabric #3 strip **AND** 1 – 5½" fabric #3 strip RST with 5½" fabric #6 strip.
- Use **Side B** of the **Precision Flying Geese & HST Ruler** to cut 8 – 5½" triangle pairs (16 triangles total) from fabrics #1 and #3 **AND** 8 – 5½" triangle pairs (16 triangles total) from fabrics #3 / #6 for HSTs.
- Chain stitch the units together on the long side of the triangles.
- Press seams *toward fabric #3* (for the #1 / #3 HSTs) and *toward fabric #6* (for the #3 / #6 HSTs).
- HSTs should measure 5½" x 5½" (unfinished). Trim all dog ears and square-up if necessary.
- Make 8 of each #1 / #3 and #3 / #6.

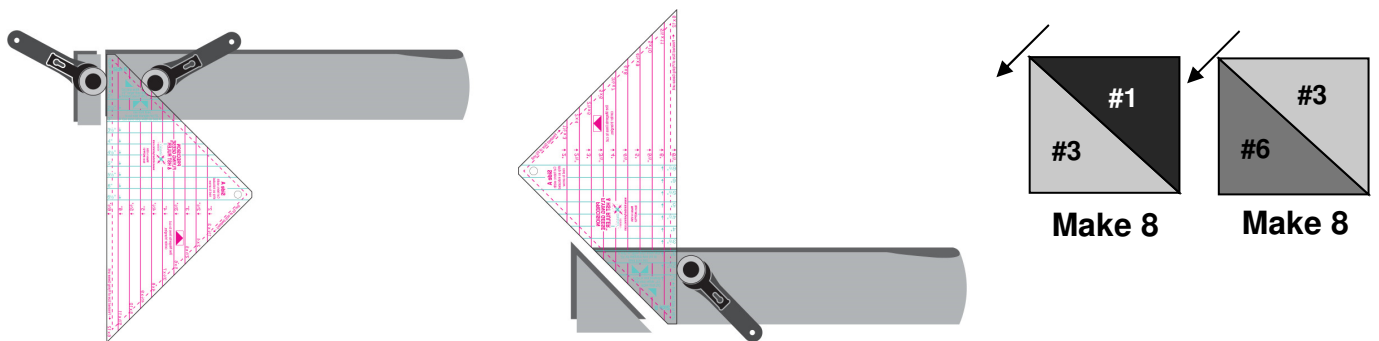

OR

Traditional method:

- Place 4 – 5⅞" squares of fabrics #1 and #3 RST and 4 – 5⅞" squares of fabrics #3 and #6 RST.
- Draw a diagonal line on the back of a fabric square and stitch ¼" on both sides of the diagonal line.
- Cut on the drawn line.
- Press seams toward fabric #3 (for the #1 / #3 HSTs) and toward fabric #6 (for the #3 / #6 HSTs).
- HSTs should measure 5½" x 5½" (unfinished). Trim all dog ears and square-up if necessary.
- Make 8 of each #1 / #3 and #3 / #6.

